

HAMMER MILL - HA 800

**HIGHLY WEAR-RESISTANT.
IRRESISTIBLE.
ENTIRELY ENCLOSED.**

**ALL OF YOUR REQUIREMENTS
ARE IN EXPERT HANDS WITH US.**

As an owner-managed company, we are able to offer you personal consulting, short reaction times and customized solutions. Combined, of course, with comprehensive services and first-class quality made in Bavaria.

Core competencies:

- Shredding machines
- Plant engineering
- Service

We look forward to your challenges!

Welcome to ERDWICH!



HAMMER MILL - HA 800



**INCREASE YOUR
PRODUCTIVITY
NOW!**

The flexible design of the rotor-stator principle, adapted to the different materials being processed, can be installed both for the breaking-up of materials and as ball-forming machine, offering therefore a wide-ranging scope of applications.

Owing to its compact construction and the constructive set-up, the hammer mills from Erdwich excel by maximum profitability and particularly fine breaking-up of material, which is of vital importance for effective further processing.

Technical advantages

- Processing of electronic waste as a preliminary stage or a subsequent stage after the customary ripper technology
 - Processing of aluminium profiles and composite materials
 - Preparation of shredder light fraction for subsequent separation
 - Recycling of printed circuit boards, IC components and small electronic equipment
 - Grinding of non-ferrous composite materials with subsequent ball forming
 - Processing of large-volume metal swarf
 - Preparation of tyre wires for subsequent separation of rubber and iron
 - Slag processing
 - etc.
- Highly wear-resistant, individually removable grinding tools
 - Different forms of hammer and beater
 - Variable rotor equipment of 4 to 8 beater rows
 - Grinding wall arrangement and number of grinding plates adaptable
 - Closed construction enables dust-free operation and possibility of rendering inert
 - Hydraulically pivotable housing wall for easy access for maintenance and service work
 - Mechanical protection against overload with ejection system for extraneous materials
 - PLC control system with protection against overload and optional frequency control



ERDWICH ZERKLEINERUNGS-SYSTEME GMBH

Gewerbestraße 6
D-86859 Igling
Phone: +49 (0)8191 - 96 52 - 0
Fax: +49 (0)8191 - 96 52 - 16
E-Mail: infoline@erdwich.de

www.erdwich.com

**TOP TECHNOLOGY FOR THE SELECTIVE
PROCESSING OF HARD AND BRITTLE MATERIALS!**

www.erdwich.com

Сделано
в Баварии

ADVANTAGES AND TECHNOLOGY

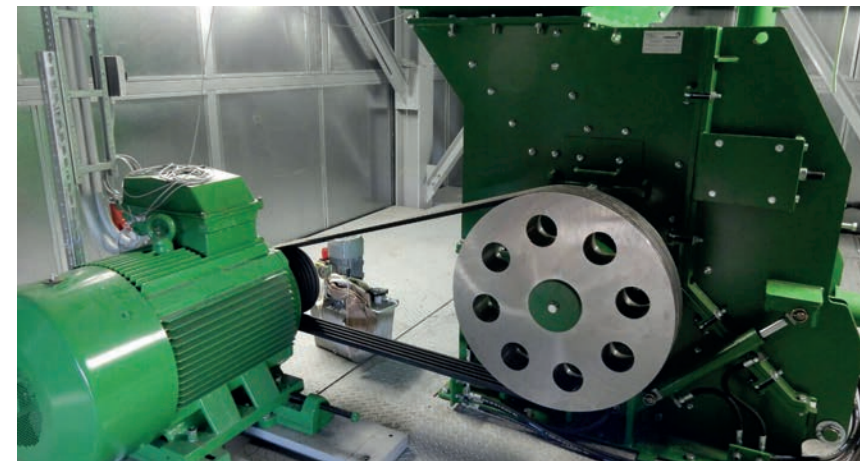

Selective and efficient shredding of hard and brittle materials!

The development of our own hammer mill technology is based on our long years of experience with different applications and the knowledge gained from it.

Using conventional technology, many materials are very difficult to break down or subject the equipment to heavy wear. The use of a variety of tools allows us to process a very wide spectrum of the most different materials.

A range of different grate baskets is used to determine the size of the output fractions as well as to form the composite materials into balls. Different rotor speeds can be adapted to the material being processed.

The well-engineered welded construction and the divisible machine housing enable quick and easy access to the tools. Due to the additionally integrated hydraulic system, the housing can be opened without major effort.

The installation of different grinding walls allows us to define precisely the grain size of the materials being processed. By means of the automatic positioning of the grinding track, we achieve a high level of safety in respect of foreign matter contained in the material, so that the grinding wall can move aside automatically in the case of excessive load.

For the selective challenges in life.
Hammer mills from ERDWICH.

INTEGRATED EXPLOSION PREVENTION AND PROTECTION

- Highest safety standards

MAINTENANCE OPENINGS FOR GRINDING PLATES

- Direct access for quick maintenance

AUTOMATIC POSITIONING OF GRINDING TRACKS

- Protection against overload through stable spring assemblies

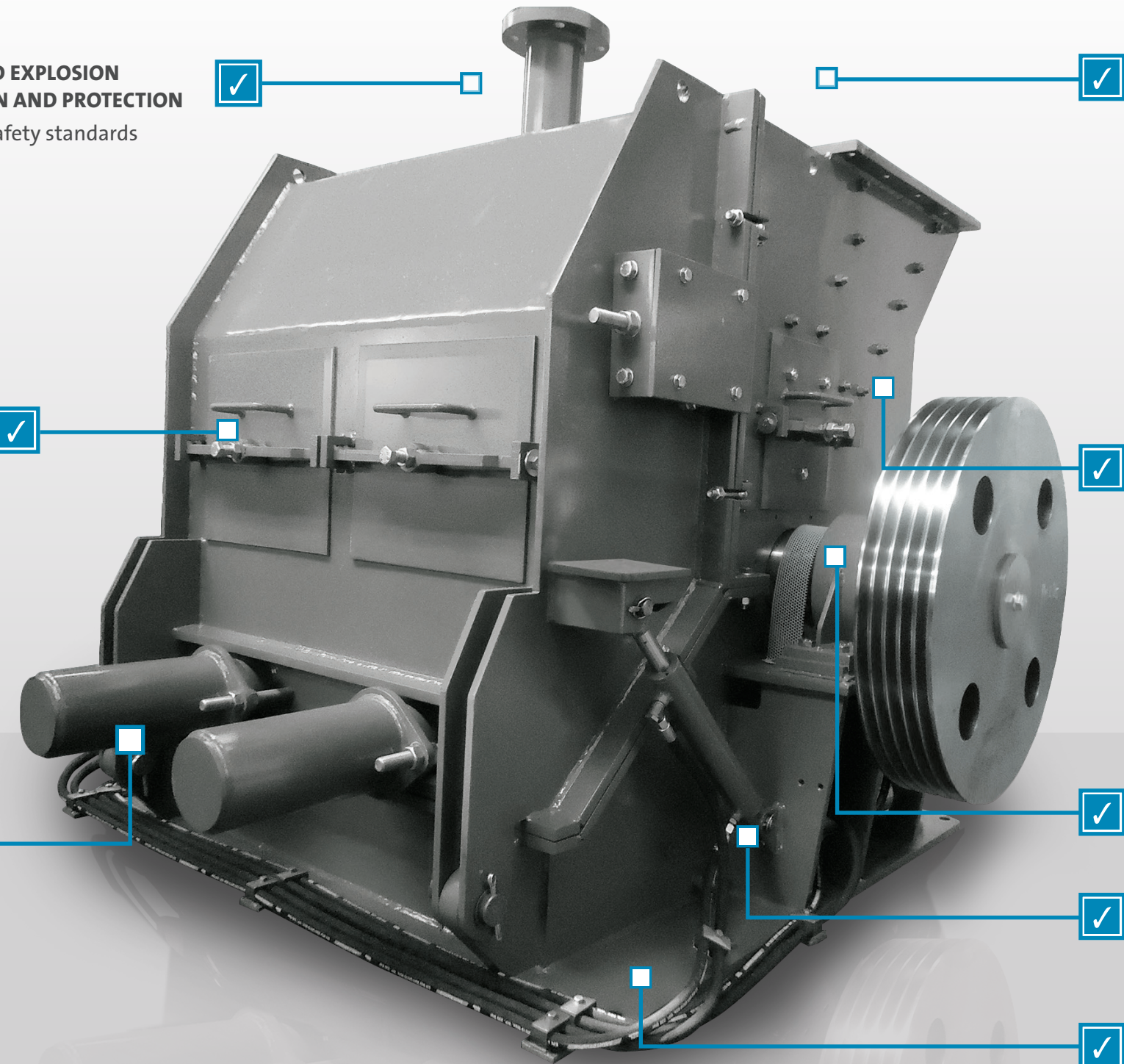

HOUSING DUST- AND GAS-TIGHT EXECUTION

- Special shaft and housing seal

CONTROLLABLE THROUGHPUT OF THE PARTICLE SIZE

- Individual adjustment of the grinding gap opening and easy change of the grinding tools
- Adjustable rotor speed

PROTECTED EXTERNAL SHAFT BEARING

HYDRAULIC HOUSING APERTURE FOR EASY ACCESS

HYDRAULICALLY EXTENDIBLE SIEVE BASKET



Technical data	HA 800/1-1000	HA 800/1-1500	Dimensions	HA 800/1-1000	HA 800/1-1500
Number of rotors	1	1	Overall length A	2,100 mm	2,100 mm
Drive power	45–132 kW	45–132 kW	Overall width B	2,100 mm	2,600 mm
Rotor diameter	610 mm	610 mm	Overall height C	1,560 mm	1,560 mm
Weight	9,000 kg	13,000 kg	Impact range/crushing D	800 mm	800 mm
Sieve grate aperture	8–100 mm	8–100 mm	Hammer area E	1,000 mm	1,500 mm
			Inlet Port F (LxD)	1,060 x 585 mm	1,560 x 585 mm

